



www.hirschmann.com

**HIRSCHMANN**

**PAT**

## **LOAD MOMENT INDICATOR**

**DS 85/0002**

central unit/ console

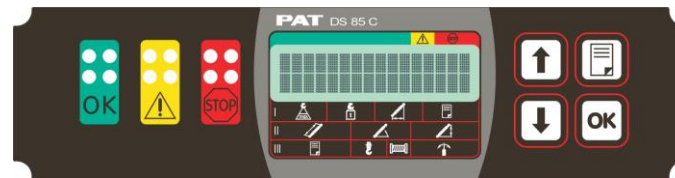

## **OPERATOR'S MANUAL**

P/N 031-300-190-165 REV D 10/05/2015



# NOTICE

Hirschmann makes no warranty of any kind with regard to this material, including, but not limited to, the implied warranties of merchantability and/or its fitness for a particular purpose.

Hirschmann will not be liable for errors contained in this manual or for incidental or consequential damages in connection with the furnishing, performance, or use of this manual. This document contains proprietary information, which is protected by copyright, and all rights are reserved.

No part of this document may be photocopied, reproduced, or translated to another language without the prior written consent of Hirschmann.

Hirschmann reserves proprietary rights to all drawings, photos and the data contained therein. The drawings, photos and data are confidential and cannot be used or reproduced without the written consent of Hirschmann. The drawings and/or photos are subject to technical modification without prior notice.

All information in this document is subject to change without notice.

## MANUAL REVISIONS

REV	DATE	NAME	DESCRIPTION
-	03/27/03	CH	ECN 03-039
A	06/16/05	SB	ECN 05-109
B	03/07/06	SB	ECN 05-201
C	02/29/08	SC	ECN 08-022
D	10/02/15	JPD	ECN 15-198



TABLE OF CONTENTS

- 1 GENERAL INFORMATION ..... 1
- 2 WARNINGS..... 1
- 3 SYSTEM DESCRIPTION..... 2
  - 3.1 OPERATING CONSOLE..... 5
  - 3.2 CONTROL IDENTIFICATION ..... 5
  - 3.3 RADIO ANTI-TWO BLOCK SYSTEM ..... 8
    - 3.3.1 Receiver ..... 8
  - 3.4 TRANSMITTER / SWITCH ..... 9
    - 3.4.1 Storage of the A2B transmitter for Travel..... 9
- 4 CONFIGURATION SETUP ..... 10
  - 4.1 SETUP OF OPERATING MODE (REEVING) ..... 10
  - 4.2 ADJUSTING THE TEXT MESSAGE LANGUAGE ..... 11
  - 4.3 SETUP OF THE RADIO ANTI-TWO BLOCK..... 12
    - 4.3.1 Setup Overview ..... 12
    - 4.3.2 LEDs..... 12
- 5 OPERATION ..... 14
  - 5.1 RECEIVER..... 14
- 6 SETUP A SENSOR/MENU OPTIONS ..... 15
  - 6.1 INSTALL SENSOR / TRANSMITTER ..... 15
  - 6.2 UNINSTALL SENSOR / TRANSMITTER ..... 19
- 7 INSTALLATION ..... 20
  - 7.1 RECEIVER..... 20
  - 7.2 LIMIT SETTING ..... 21
    - 7.2.1 ANGLE ..... 21
    - 7.2.2 RADIUS ..... 22
    - 7.2.3 TIP HEIGHT ..... 22
- 8 PRE-OPERATION INSPECTION AND CALIBRATION VERIFICATION..... 23
  - 8.1 MACHINES WITH ONLY A MAIN HOIST ..... 23
  - 8.2 MACHINES WITH MAIN AND AUXILIARY HOISTS ..... 23
  - 8.3 INSTALLATION OF ANTI TWO-BLOCK RETAINER IN LOCKING POSITION..... 24
  - 8.4 REMOVAL AND STORAGE OF THE ANTI TWO-BLOCK RETAINER ..... 24
  - 8.5 PRE-OPERATION INSPECTION AND CALIBRATION VERIFICATION ..... 25
- 9 SERVICE AND MAINTENANCE ..... 26
- 10 TROUBLESHOOTING ..... 27
  - 10.1 GENERAL ..... 27
  - 10.2 SERVICE SCREEN ..... 27
  - 10.3 MALFUNCTION TABLE ..... 28
  - 10.4 OPERATING ERRORS..... 28



## 1 GENERAL INFORMATION

The PAT Load Moment Indicator<sup>1</sup> (LMI) has been designed to provide the crane operator with the essential information required to operate the machine within its design parameters.

Using different sensing devices, the Load Moment Indicator monitors various crane functions and provides the operator with a continuous reading of the crane's capacity. The readings continuously change as the crane moves through the motions needed to make the lift.

The LMI provides the operator with information regarding the length and angle of the boom, working radius, rated load and the total calculated weight being lifted by the crane.

If non permitted conditions are approached, the Load Moment Indicator will warn the operator by sounding an audible alarm, lighting a warning light and locking out those functions that may aggravate the crane's condition.

## 2 WARNINGS

The LMI is an operational aid that warns a crane operator of approaching overload conditions and of over hoist conditions that could cause damage to equipment and personnel.

The device is not, and shall not, be a substitute for good operator judgment, experience and use of accepted safe crane operating procedures.

The responsibility for the safe crane operation shall remain with the crane operator who shall ensure that all warnings and instructions supplied are fully understood and observed.

Prior to operating the crane, the operator must carefully and thoroughly read and understand the information in this manual to ensure that he knows the operation and limitations of indicator and crane.

Proper functioning depends upon proper daily inspection and observance of the operating instructions set forth in this manual. Refer to Section 6. *Pre-Operation Inspection and Calibration Verification* of this handbook.



**The LMI can only work correctly, if all adjustments have been properly set. For correct adjustment, the operator has to answer thoroughly and correctly all questions asked during the setup procedure in accordance with the real rigging state of the crane. To prevent material damage and serious or even fatal accidents, the correct adjustment of the LMI has to be ensured before starting the crane operation.**

<sup>1</sup> LOAD MOMENT: generally the product of a force and its moment arm; specifically, the product of the load and the load-radius. Used in the determination of the lifting capacity of a crane

### 3 SYSTEM DESCRIPTION

The PAT Load Moment Indicator consists of a central micro processor unit/operating console, length/angle sensor, pressure transducers, and anti-two block switches.

The system operates on the principle of reference/real comparison. The real value, resulting from the pressure measurement is compared with the reference data, stored in the central processor memory and evaluated in the micro processor. When limits are reached, an overload warning signal is generated at the operator's console. At the same time, the aggravating crane movements, such as hoist up, telescope out and boom down, will be stopped.

The fixed data regarding the crane, such as capacity charts, boom weights, centers of gravity and dimensions are stored in memory in the central processor unit. This data is the reference information used to calculate the operating conditions.

The operating modes are selected by the operating mode key on the console by scrolling through the text messages defining the boom truck configuration.

The crane load is measured by pressure transducers attached to the piston and rod side of the hoist cylinders.

Boom length and boom angle are transmitted by length/angle CAN bus node mounted on the side of the boom in the angle sensor box. The length sensor/cable reel is mounted inside the base which measures the boom length.

The PAT RATB works like our normal Anti-Two-Block. It alerts to an impending two-block condition. This alert can come in the form of an audible alarm and visual LED or with the optional function lockout if the crane is so equipped.

The iSENS HES-W1 is a battery operated limit switch for the detection of the hoist limit condition, e.g. on the lifting rope of a crane. The wireless module with integrated battery compartment serves the wireless transmission of the hoist limit condition to suitable wireless receivers. An operating period of up to 2 years is achieved by the use of power-saving techniques when using lithium batteries.

The receiver is mounted into a receiver box located near the operating station. The receiver box provides the following indications: Power, Online, Info, and Low Battery. The receiver will work 10..30VDC and fused to 1 Amp.



**Fig. 1: Components of the LMI system PAT DS 85**

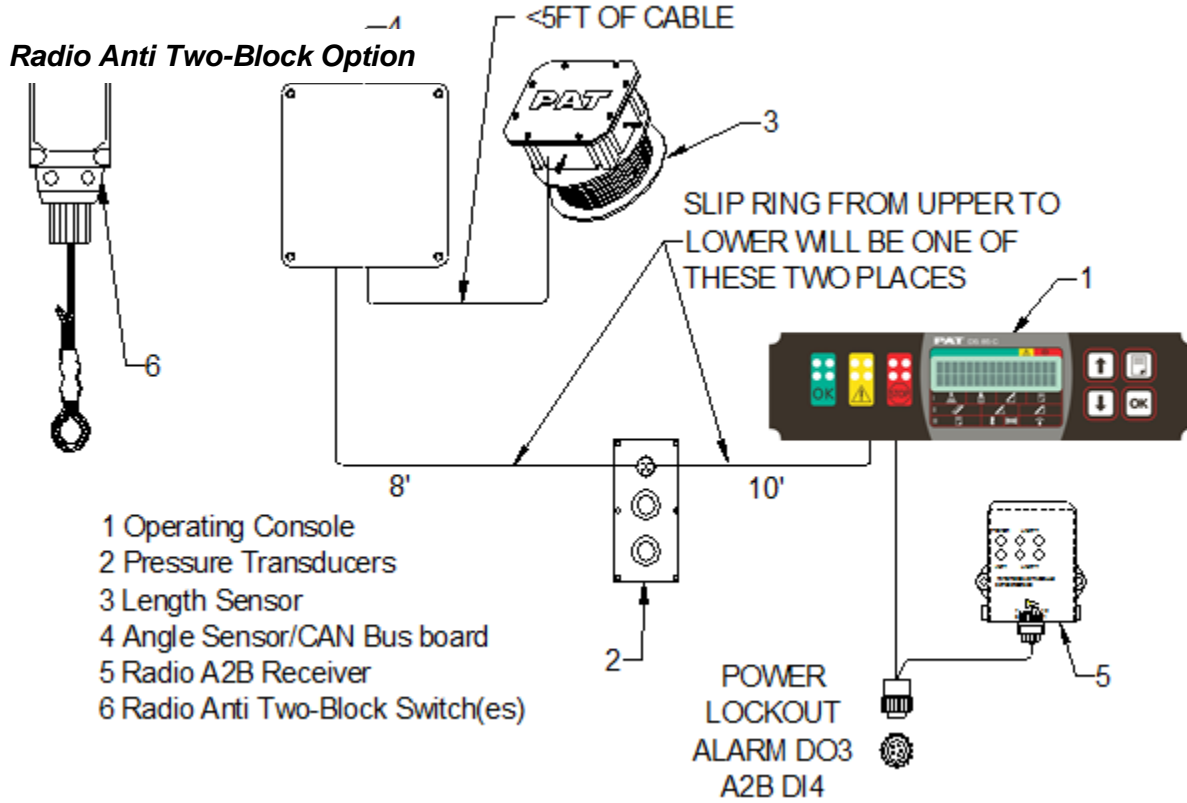

**Hardwired Anti Two-Block Option**

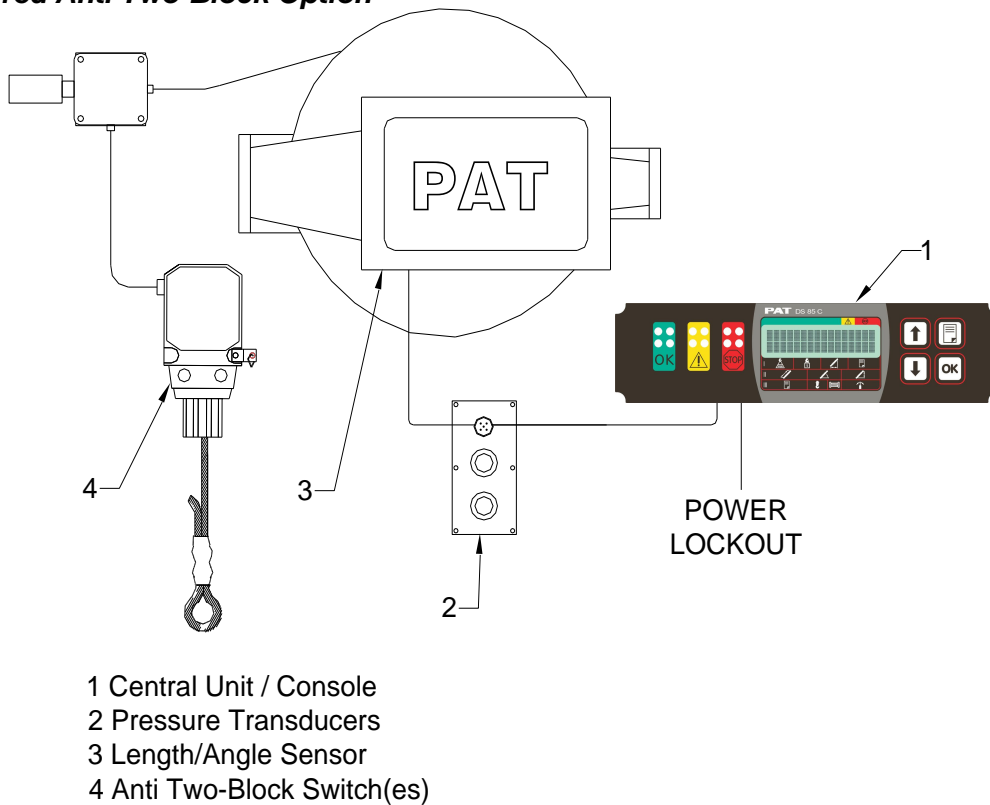

## System Function

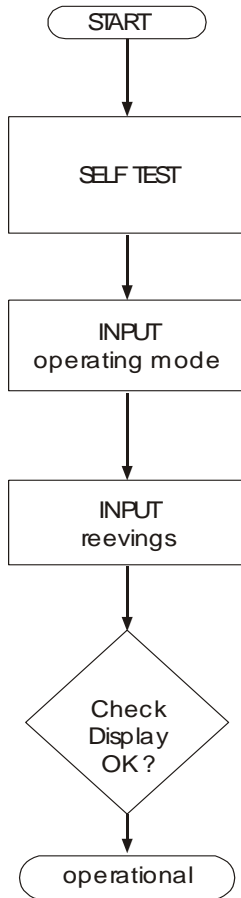

Upon switching on, the system starts with an automatic test of the LMI system, of lamps and audible alarm.

If the system was turned off for more than two hours, the setup configuration has to be entered after the system test.

First, the operating mode is determined scrolling through the list of allowable operating modes.

Next is the input of the reevings.

Check displayed values and for Operational Errors. Now the LC display shows inputs as defined by the roman numeral display setting selected.

The system is ready for operation.

### 3.1 OPERATING CONSOLE

The console has 3 functions:

- inputs by the crane operator (operating mode, reeving)
- input of geometry limit values and signalization of exceeded limit values
- display of important operating information and service data.

The operator's console is mounted by the operating station in the operator's field of vision. For a better identification of displays and operating elements, they are continuously backlit during operation.

### 3.2 CONTROL IDENTIFICATION

This unit contains a display and different controls which are described as follows:

*Legend to Fig 2:*

- 1 Data display (backlit)
- 2 Color marking for bargraph (utilization)
- 3 Symbols
- 4 Indicator normal utilization
- 5 Indicator prewarning overload
- 6 Indicator overload
- 7 Selection button up
- 8 Selection button down
- 9 OK acknowledgement button
- 10 Operation mode key (reeving)

**Fig. 2a: Operating Console**

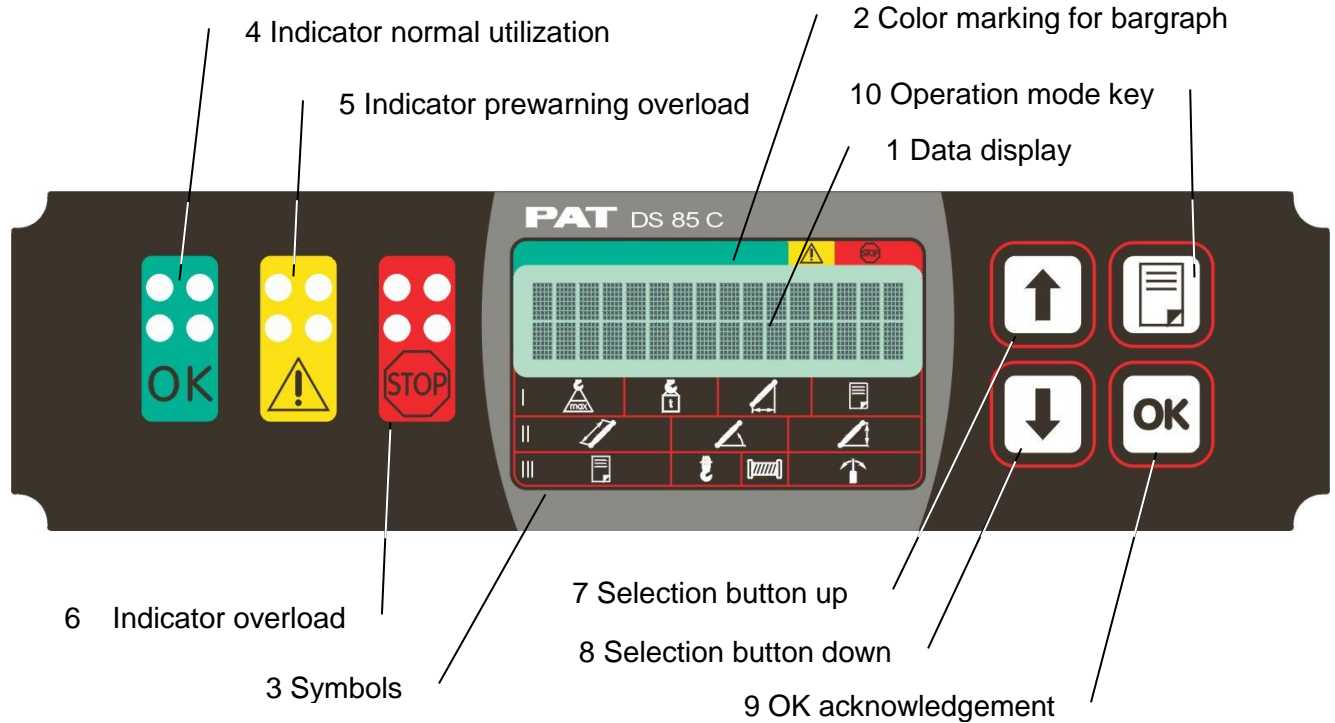

## 1 Data display



The *Data display* (1) is an illuminated LC display which shows several values.

The figure shows the display during normal operating, limit setting, error codes, and service information.

## 2 Utilization bar graph

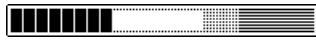

This utilization bar graph display (2) indicates how much of the loader's rated capacity is being used. (utilization)

As the rated capacity of the loader changes as it is moved through its various motions, the utilization display will constantly change as well.

The bar graph is marked with different colors:

- green: and safe section (0%...90% of rated cap.)
- yellow: prewarning section (90%...100% of rated cap.)
- red: overload section (>100% of safe working load)

## 3 Symbols for display values



*Symbols* (3) below the display data are the designators for the values displayed above the marked areas.

The display level label (I or II, at the left) marks the level selected.

Display level selection is made by way of the selection buttons *up* (7) or *down* (8), respectively.

## 4 Normal utilization Indicator



This green lamp will light up when the load on the crane is below 90 % of the loader's rating capacity, indicating that the utilization is normal

## 5 Prewarning indicator



The yellow *prewarning light* (5) will light up when the load on the crane is over 90 % of the crane rating, indicating that an overload condition is approaching



Warns the operator to continue his crane operation with caution.

## 6 Overload indicator



The red *overload light* (4) warns the operator that a rated load condition has been reached.

## 7 up Selection button



This selection button selects display elements during the following functions:

- Selection of display level
- Selection of language
- Selection of operating mode (reeving)

## 8 down Selection button

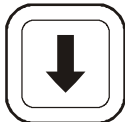

This selection button selects display elements during the following functions:

- Selection of display level
- Selection of language
- Selection of operating mode (reeving)

## 9 OK Acknowledgement button



An acoustical alarm message can be acknowledged by activation of this selection button.

However, audible alarm message acknowledgement can be activated after 5 seconds alarm duration, at the earliest.

The acoustical alarm will sound upon the following events:

System test, overload condition, malfunction of the load moment indicator system, or after recognized operator errors.

## 10 Operating mode Selection button (Select Reeving)



The function Setup operating mode (reeving) is activated by this selection button.

The setup procedure is described in chapter 4.2.

### **WARNING**

**The correct setting of the Operating Mode is of utmost importance for the proper function of the system and the loader. Therefore, only operators who are thoroughly familiar with the load capacity charts and the use and operation of the system shall set the Operating Mode.**

**Failure to properly program the LMI with the correct operating mode code may result in property damage or serious bodily injury or death to personnel.**

**To assure the crane is properly programmed, verify that the operating mode code, shown at data display (1) and the load capacity chart match the lifting configuration of the crane.**

## 3.3 RADIO ANTI-TWO BLOCK SYSTEM

### 3.3.1 Receiver



**iFLEX TRS12 Radio Anti-Two-Block Receiver and Receiver Box**

## 3.3.1.A LEDs:

1. 'POWER'	RED	Operating status.
2. 'ONLINE'	GREEN	Indicator for registered wireless limit switches, channels 1 and 2.
3. 'LOW BATT'	YELLOW	Indicator for weak sensor batteries, channels 1 and 2.
4. 'INFO'	RED	Indicator for hoist limit signal.



## 3.4 TRANSMITTER / SWITCH

The transmitter and battery housing are made of a special plastic that resists impact and will not become brittle even in low temperatures.

## Transmitter LED

The transmitter has an LED on the bottom for diagnostics. The LED should be on when in a two-block condition or when the weight is lifted. The LED will flash rapidly during a 2-block condition and will stop flashing after the switch is in a two-block condition for more than 15 seconds. The LED will flash randomly approximately every 2 seconds when the switch is transmitting. When in sleep mode, the LED will not flash.

## 3.4.1 Storage of the A2B transmitter for Travel

The weight should remove from the switch when traveling to extend battery life. The system is in permanent lockout and the system will not function until the chain is unhooked. To use the feature, attach any part of the chain into the hook. When it is desired to use the switch again, simply unhook the chain to allow the switch to close.



**⚠ WARNING**

The weight and chain must be hung from the switch and/or the chain must be unhooked before the crane is operated.

## 4 CONFIGURATION SETUP

The LMI setup procedure allows the operator to input the crane operating mode through the text displays and enter the reeving or parts of line used. The operator must correctly setup the Load Moment Indicator system when the crane operation configuration has been changed or after turning on the system powered.

### 4.1 SETUP OF OPERATING MODE (REEVING)



**The correct setting of the Operating Mode Code (Reeving) is of utmost importance for the proper function of the system and the crane. Therefore, only operators who are thoroughly familiar with the load capacity charts and the use and operation of the system shall set the Operating Code.**

**Failure to properly program the LMI with the correct operating mode code may result in property damage or serious bodily injury or death to personnel.**

**To assure the crane is properly programmed, verify that the operating mode code shown at data display (1) and the load capacity chart match the lifting configuration of the crane.**

#### ...at power up:

- System performs a system test and will display the software version in the DS85 system 7-10 seconds.
- The system will then display an operating mode scroll through the operating codes and select the mode matching the crane configuration then



Press

- Reeving will be displayed, scroll up or down to display the correct parts of lines configured on the crane



Press

- The system should then be ready to operate.

#### ...during operation:

- To change the operating mode or reeving during



operation Press and complete the procedure described above in the 'at power up' column.



## 4.2 ADJUSTING THE TEXT MESSAGE LANGUAGE

Text messages can optionally be displayed in German, English, French or Italian. It is not necessary to repeat this language adjustment when starting the system as it will be stored until the next adjustment. The procedure is described as follows:

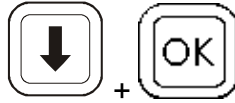

To start function press

The following language displays can be scrolled through:

ENGLISH
0
FRANCAIS
1
DEUTSCH
2
ESPANOL
3



press to select the language shown on the screen.

Note: The language will only displayed if the manufacturer defines the operating mode verbiage.

### 4.3 SETUP OF THE RADIO ANTI-TWO BLOCK

#### 4.3.1 Setup Overview

The PAT RATB is easily configured to communicate with up to 2 transmitters. Wireless hoist limit switches are registered or deleted by depressing the programming button for the appropriate interval. A visual confirmation can be observed via the online LED of the respective channel.

The button is located inside the housing of the device and is only accessible after opening the housing.

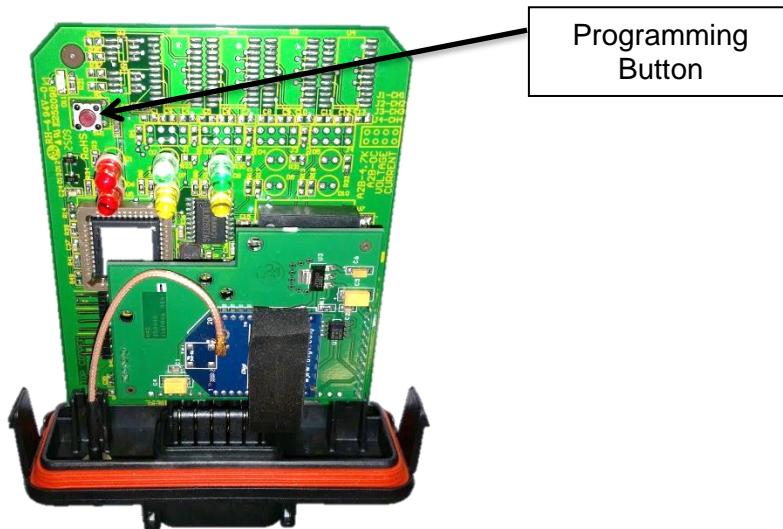











#### 4.3.2 LEDs

There are 6 LEDs on the front panel of the device, which indicate the status of various operating conditions.



The meaning of the signals can be taken from the table:

	off: 	lights: 	flashes slowly: 	flashes rapidly: 
<b>POWER</b> 	No supply voltage present	Supply voltage is present		
 <b>INFO</b>		Hoist limit switch has triggered <i>or</i> radio link to a hoist limit switch interrupted		
<b>ONLINE</b>  	No sensor registered to this channel	Sensor registered to this channel and ready for operation	During the registration of a new hoist limit switch <i>or</i> sensor in 'sleep' mode	Radio link to the sensor on this channel interrupted
  <b>LOW BATT</b>		Batteries of the sensor on this channel are almost exhausted Replace the batteries soon!		

## 5 OPERATION

### 5.1 RECEIVER

The iFLEX TRS 12 switches itself on as soon as the supply voltage is present. The red 'Power' LED lights up. After switching on, the system begins with a self-diagnostic

routine. The self-diagnosis takes approx. 3 seconds. During these tests the 'Online' and 'Low Batt' LEDs additionally light up alternately with a test pattern: alternating green and yellow.

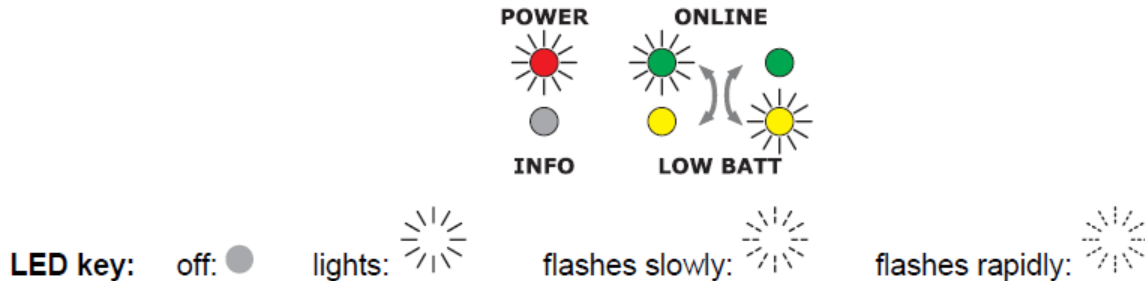

If an alarm condition exists, investigate and clear the condition before operating the system.

If no wireless hoist limit switches have been registered yet, only the 'Power' LED should be lit after completion of the self-diagnosis. If wireless hoist limit switches have already been registered, the 'Online' LED of the respective channel additionally lights up, indicating that the radio link has been established.

If a 'Low Battery' LED lights up, this means that the battery set in the respective wireless sensor is exhausted (remaining capacity < 6.5 %) and must be replaced as soon as possible.

If the 'Info' LED lights up, this means that one of the connected wireless hoist limit switches has reported 'hoist limit'. At the same time, the relay contact opens and there is no voltage at the signal output. The LED may also light up briefly after the iFLEX TRS 12 is switched on, until the radio link to the registered hoist limit switches has been established. If the LED remains lit, this means that the radio link to a registered wireless hoist limit switch is interrupted. In this case the 'Online' LED assigned to the respective channel also flashes.

If an 'Online' LED flashes rapidly after conclusion of the self-diagnosis, this means that the radio link to the wireless hoist limit switch on the indicated channel is interrupted. The 'Info' LED also lights up at the same time.

Slow flashing of an 'Online' LED in conjunction with the lighting up of the 'INFO' LED means that the wireless hoist limit switch on the indicated channel is in sleep mode. This mode is activated automatically if the hoist limit switch remains in the hoist limit condition for a lengthy period of time. This function serves to reduce the power requirement of the hoist limit switch. The function is reset automatically upon the next switching of the hoist limit switch.

## 6 SETUP A SENSOR/MENU OPTIONS

### **WARNING**

While the programming button is held or in the calibration process, the sensor outputs will not correctly indicate the status of other installed sensors. Correct operation will return when the menu is exited or calibration process is complete or system is powered off/on.

Every wireless hoist limit switch to be used (maximum 2) must be registered once to the **iFLEX TRS 12** for operation. The wireless hoist limit switch does not need to be registered again following a battery change. Re-registration is necessary after exchanging a wireless hoist limit switch. Wireless hoist limit switches that are not to be used any longer must be deleted and deactivated by removing the batteries.

### 6.1 INSTALL SENSOR / TRANSMITTER

The programming button is located inside the housing of the device and is only accessible after opening the housing.

- First of all, disconnect the iFLEX TRS 12 from the power supply by pulling out the central plug.
- Follow the procedure described below to open the housing:

#### **HINT**

A flat-blade screwdriver with a blade width of 4.5 - 5.5 mm is best suited for opening the housing.

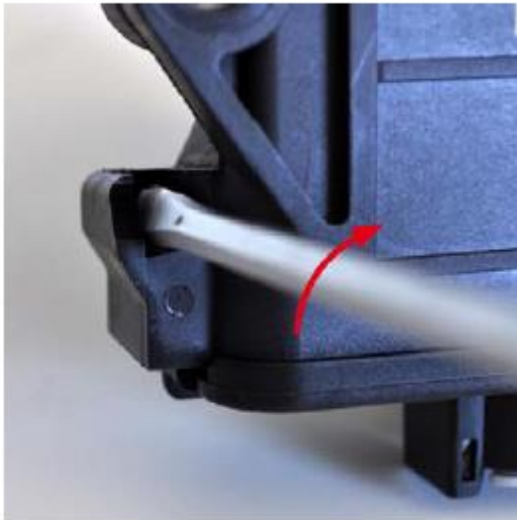

▲ **1.** By means of a slight twisting movement of the screwdriver, press the latches (on both sides of the housing at the rear) carefully towards the housing and in this way unlock the circuit board

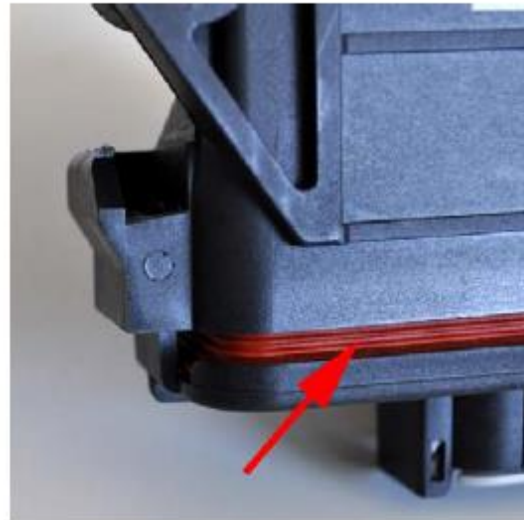

▲ **2.** The housing seal will be visible if the circuit board has been unlocked correctly



▲ 3. Carefully pull the circuit board out of the housing

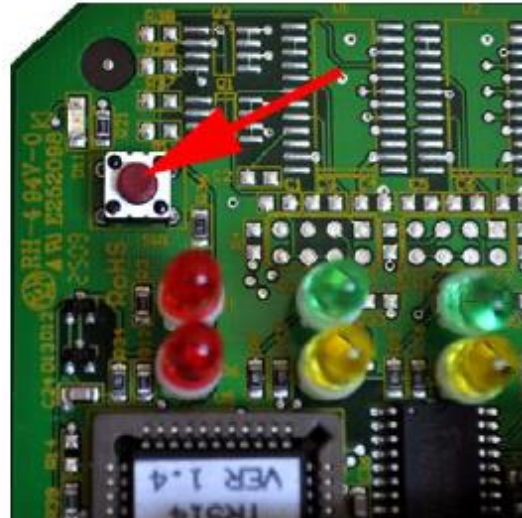

▲ 4. View of the programming button and the LEDs on the circuit board

Follow the procedure described below to register a wireless hoist limit switch.

- The wireless hoist limit switch should be no more than 1 metre away from the iFLEX TRS 12 during the registration phase.
- Connect the iFLEX TRS 12 to the power supply again. (See also Chapter 4.1)

## HINT

Keep a fresh set of batteries at the ready for the registration.



▲ 1. First of all, open the battery compartment of the wireless hoist limit switch to be registered by undoing the cover screws and removing the cover of the battery compartment.



▲ 2. Remove the batteries

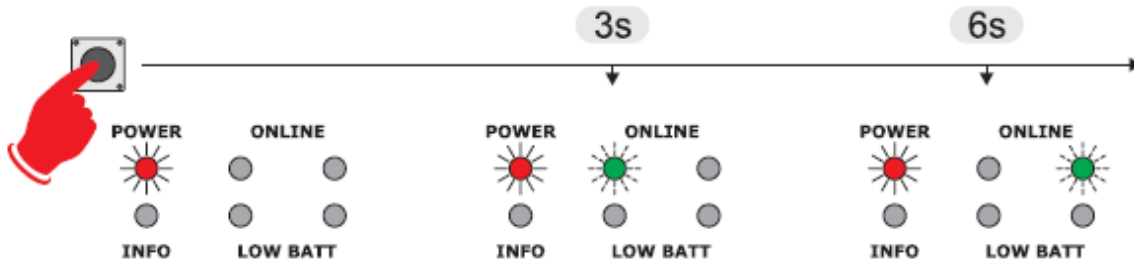

▲ **3.** Press and hold the programming button of the iFLEX TRS12 until:

- Online LED1 flashes (for the registration of a wireless hoist limit switch to **channel 1**) or
  - Online LED2 flashes (for the registration of a wireless hoist limit switch to **channel 2**)
- and then release the button.



▲ **4.** Now insert the batteries into the battery compartment of the wireless hoist limit switch to be registered, observing the correct polarity.



▲ **5.** Observe the LED on the underside of the housing. This should light up with short pulses. Now fit the cover of the battery compartment.

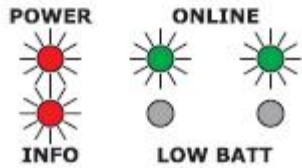

▲ 6. The wireless hoist limit switch is correctly registered if the respective Online LED 1 and/or LED 2 is lit steadily.

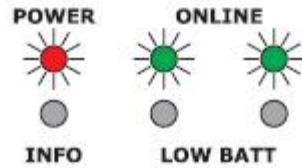

▲ 7. Now pull on the rope of the wireless hoist limit switch for 5 secs. The system is working perfectly if the 'INFO' LED extinguishes within this time. The wireless hoist limit switch is now ready to be mounted.



▲ 8. Carefully slide the circuit board into the guide rails in the housing. Make sure that the foam strip is positioned as shown.



▲ 9. Lock the circuit board by applying strong pressure to the underside of the housing (clearly audible click at both sides).

### RADIO ATB ANTENNA INSTALLATION

Mount the antennas in identical positions (90° / perpendicular to the boom) and in a direct line between transmitter and receiver, ensuring that no obstructions will interfere with the transmission of the radio signal.

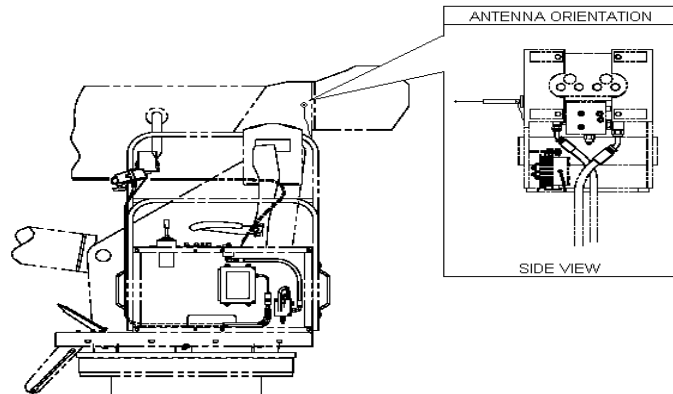
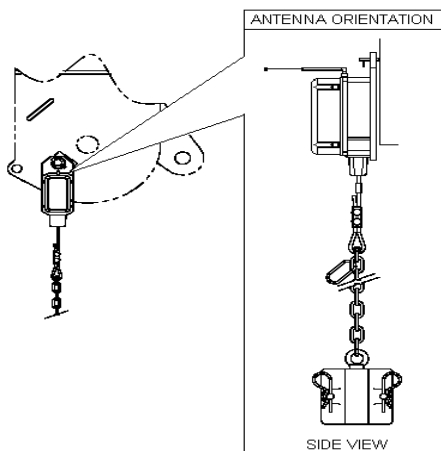



## 6.2 UNINSTALL SENSOR / TRANSMITTER

Wireless hoist limit switches that are not to be used any longer must be deleted and deactivated by removing the batteries.

Follow the procedure described below to delete a wireless hoist limit switch.

1. Open the housing of the iFLEX TRS 12 as described in chapter 5.1.

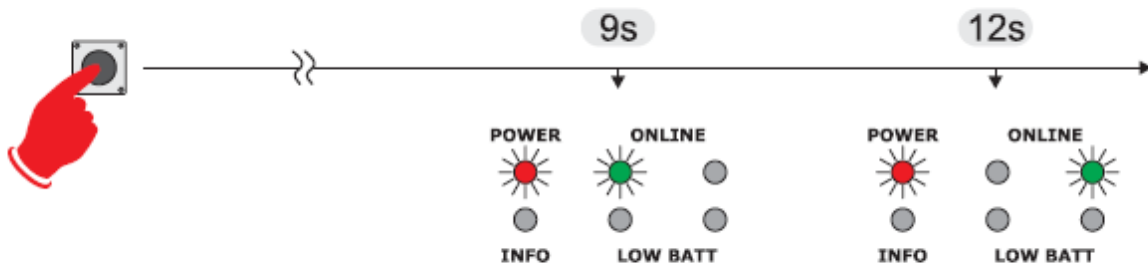

- ▲ 2. Press and hold the programming button of the iFLEX TRS12 until:

- Online LED1 lights steadily (for the deletion of a wireless hoist limit switch from channel 1) or
  - Online LED2 lights steadily (for the deletion of a wireless hoist limit switch from channel 2)
- and then release the button.

**The wireless hoist limit switch is deleted as soon as the respective 'Online' LED has extinguished.**

If you have missed the desired time for releasing the programming button or have inadvertently selected the wrong channel, press the button again until the LED signals the desired function.

## 7 INSTALLATION

### 7.1 RECEIVER

The receiver module should be mounted so the operator can view the LEDs and setup the system for operation. The location of the receiver should be in direct line of site of the transmitter and blocked by as little metal as possible between the transmitter and receiver. However, in some cases the receiver has been installed surrounded by metal and worked well. The location needs to be tested before mounting the hardware. If the signal is lost, the box/receiver indicates a link error.

Securely attach the receiver onto a solid surface using the mounting holes.

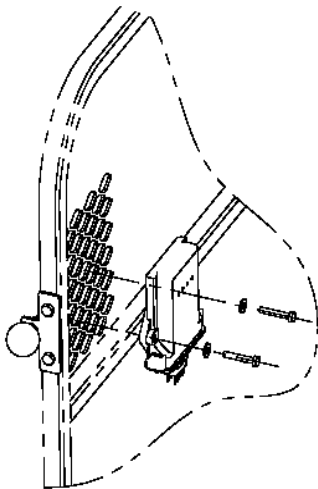

Ensure both the 12 pin header and the Deutsch plug are firmly snapped and properly seated into the enclosure during installation.

*\* An initial "click" will be heard when the when the header is inserted into the enclosure. An additional "click" will indicate the header is seated properly in place.*

**CORRECT**





**INCORRECT**



## 7.2 LIMIT SETTING

The procedure is described as follows:

To start function press  + 





The display will define the existing limits set, press  or 

The following limits displays can be scrolled through:

ANGLE  
RADIUS  
TIP HEIGHT  
EXIT

press  to select the limit marked at the upper left of the screen.

### 7.2.1 ANGLE



 SET MAX. ANGLE 

MOVE BOOM TO MAX. ANGLE DISPLAYED 

MAX. ANGLE ANGLE XX.X DEG 

ACCEPT MAX ANGLE XX.X DEG 

OR  EXIT 

 SET MIN. ANGLE 

MOVE BOOM TO MIN. ANGLE DISPLAYED 

MIN. ANGLE ANGLE XX.X DEG 

ACCEPT MIN. ANGLE XX.X DEG 

OR  EXIT 

 DELETE LIMIT 

 EXIT 

7.2.2 RADIUS  SET MAX. RADIUS MOVE BOOM TO MAX. RADIUS DISPLAYED MAX. RADIUS XX.X FT. ACCEPT RADIUS XX.X FT. OR  EXIT  SET MIN. RADIUS MOVE BOOM TO MIN. RADIUS DISPLAYED MIN. RADIUS XX.X FT. ACCEPT RADIUS XX.X FT. OR  EXIT  DELETE LIMIT  EXIT 7.2.3 TIP HEIGHT  SET MAX. TIP HEIGHT MOVE BOOM TO MAX. TIP HEIGHT DISPLAYED MAX. TIP HEIGHT XX.X FT. ACCEPT TIP HEIGHT XX.X FT. OR  EXIT  DELETE LIMIT  EXIT EXIT EXIT

## 8 PRE-OPERATION INSPECTION AND CALIBRATION VERIFICATION

Before operating the crane, the following electrical connections must be checked to ensure that the system is properly connected for the crane configuration.

### 8.1 MACHINES WITH ONLY A MAIN HOIST

Be sure the weight of the anti two-block switch is properly installed on the main hoist load line. With even parts of hoisting line, the weight shall be attached to the dead-end line. With odd parts of hoisting line, the weight shall be attached to the line of lowest speed.

If the boom extension is in the operating position and no load line is being used on main boom, to prevent injury or damage to equipment, the weight shall be removed from main boom switch. In that case the anti two-block switch has to be locked with the red Anti Two-Block Retainer, which is fixed with a red lanyard (not shown) at the anti two-block switch.



**Failure to re-position the anti two-block switch weight will prevent the overhoist system from functioning properly. No weight shall be on the main hoist anti two-block switch when the boom extension is being used.**

### 8.2 MACHINES WITH MAIN AND AUXILIARY HOISTS

If the crane works with boom extension and there are two switches. The weight attached to the main hoist anti two-block switch shall be removed. In that case the anti two-block switch has to be locked with the red Anti Two-Block Retainer, which is fixed with a red lanyard at the anti two-block switch (described in the following pages). Then the weight shall be reattached to the boom extension anti two-block switch.

### 8.3 INSTALLATION OF ANTI TWO-BLOCK RETAINER IN LOCKING POSITION

Procedure (see Fig. 1 and 2):

1. Pull the cable out of the switch and bend back parallel to the boom and hold (1).
2. Slide the retainer from left side with its slot over the cable between the crimped stop and the switch (2). Push it firmly straight onto the cable guide of the Anti Two-Block switch (3).

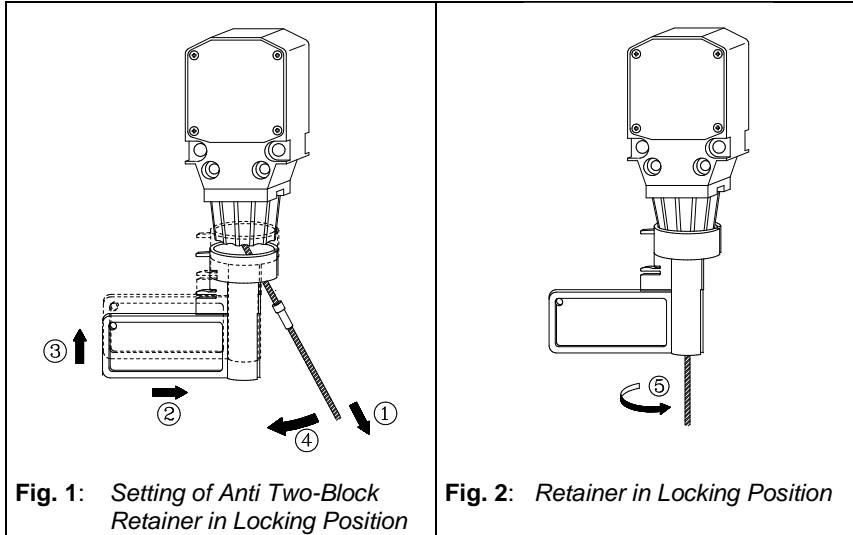

3. Straighten the cable completely into the slot and release the cable (4).
4. Turn the flag of the retainer for best visibility for the operator (5).

### 8.4 REMOVAL AND STORAGE OF THE ANTI TWO-BLOCK RETAINER

Procedure (see Fig. 3 and 4):

1. Pull the cable out of the switch (1) and bend back parallel to the boom and hold (2).
2. Move the retainer down (3) and then left (4) to remove it from the Anti Two-Block switch. Release the cable.
3. For storage slide the retainer from right side (5) over the Anti Two-Block switch until the clips (A) lock into the holes (B).

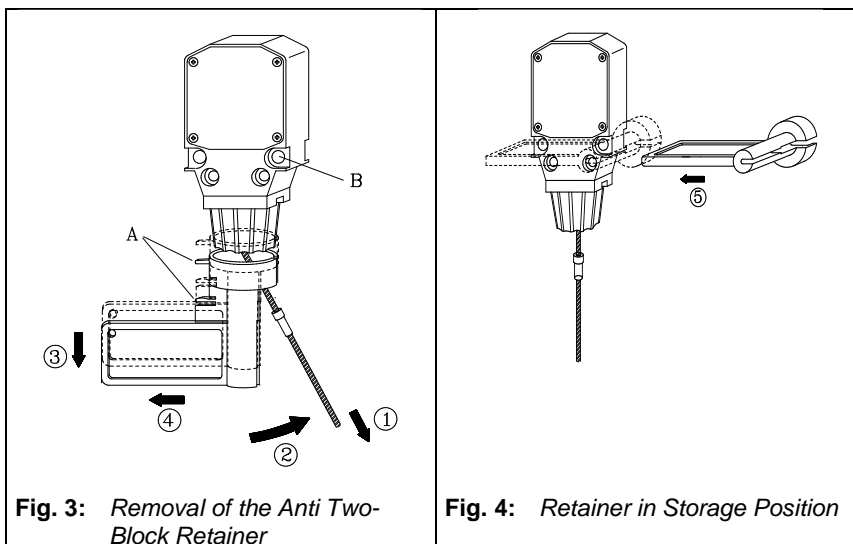

## 8.5 PRE-OPERATION INSPECTION AND CALIBRATION VERIFICATION

After the electrical connections have been checked to insure that the system is properly connected for the crane configuration, the following checks shall be made:

1. Check the electrical wiring connecting the various parts of the system for physical damage.
2. Check the anti two-block switches and weights for free movement.
3. Check the spring-loaded cable reel to be sure it is free to rotate, has tension and the cable is reeled properly.



**The following tests shall be performed with care to prevent damage to the machine or injury to personnel. Proper functioning of the system requires successful completion of these tests before operating the machine.**

**If the light and audible alarm do not function as described and the crane movements are not stopped, the system is not working properly. The malfunction shall be corrected before operating the crane.**

If the operator cannot see the load handling device approaching the boom nose, he shall have an assistant (signal person) watch the load handling device. The operator shall be prepared to stop the machine immediately should the LMI system not function properly as indicated by lighting the red warning light (4), sounding the audible alarm and locking the crane movements, hoist up, telescope out and boom down.

1. Check the anti two-block alarm light (4) and the audible alarm by performing one of the following tests:
  - a) By manually lifting the weight attached to the anti two-block switches. When the weight is lifted, the audible alarm should sound, the anti two-block alarm light (4) should light.
  - b) Slowly raise the main boom load handling device to create a potential two-block condition. When the load handling device lifts the weight, the audible alarm should sound, the anti two-block alarm light (4) should light and the motion of the load handling device should be stopped. Lower the load handling device slightly to eliminate this condition.
  - c) Slowly lower the boom to create a potential two-block condition. When the load handling device lifts the weight, the audible alarm should sound, the anti two-block alarm light (4) should light and the boom lowering function should be stopped. Lower the load handling device slightly to eliminate this condition.
  - d) Slowly extend (telescope) the boom to create a potential two-block condition. When the load handling device lifts the weight, the audible alarm should sound, the anti two-block alarm light (4) should light and the boom telescope out function should be stopped. Lower the load handling device slightly to eliminate this condition.
2. If the crane is equipped with a boom extension, repeat the test procedure for the boom extension anti two-block switch. Check that the display of the main boom length agrees with the actual boom length.
3. Check that the display of the main boom angle agrees with the actual boom angles.
4. Check that the display of the operating radius of the crane agrees with the actual radius.
5. Check the load display by lifting a load of known weight.

## 9 SERVICE AND MAINTENANCE

Daily maintenance of the load moment indicator consists of inspecting:

1. The electrical wiring connecting the various parts of the system.  
If electrical wiring is damaged, it shall be replaced immediately.
2. If the insulation is worn on the length sensor cable or cable guides are damaged, these parts shall be replaced.
3. Check the anti two-block limit switches for freedom of movement.
4. The cable reel shall be under tension to operate properly.
5. Check the pressure transducers at the hoist cylinder(s) and the connecting hoses for oil leakage.
6. During battery replacement, use caution when opening the battery cover and transmitter to avoid damage to the gasket causing moisture ingress which could corrode the batteries and terminals. Inspect the gasket surface on the transmitter for nicks or other damages that may prevent the gasket from sealing. If it appears to be damaged, a replacement gasket should be installed.

Other than correcting the problems identified in the Malfunctions Table and replacing faulty mechanical parts and cables, no other repairs shall be performed by non-expert personnel.



## 10 TROUBLESHOOTING

### 10.1 GENERAL



In case of a malfunction of the system, the display (1) will indicate a code that identifies the system malfunction.

The error codes listed in the Malfunction Table will identify various faults that can occur with the LMI. Following the Malfunction Table are pages which explain each fault and describe the action which shall be taken to correct the fault.

Faults within the electronic microprocessor shall be repaired by factory trained service personnel. When these faults occur, the competent service organization shall be contacted.

### 10.2 SERVICE SCREEN

The procedure is described as follows:

To start function press  + 

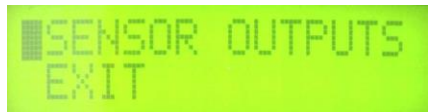

press  to select the limit marked at the upper left of the screen.

Scroll through the following screen to see piston and rod side voltages and pressures.



And length and angle voltages and measurements.



### 10.3 MALFUNCTION TABLE

Error Code	Error
<b>E01</b>	Fallen below the radius or above angle range
<b>E02</b>	Radius range exceeded or fallen below angle range
<b>E03</b>	Boom position is out of the permissible working area
<b>E04</b>	Operating mode not existing
<b>E05</b>	Prohibited length range

**NOTE:**

***If there is any Error Code displayed on the console which is not listed in the Malfunctions Table you shall call the Local Distributor.***

### 10.4 OPERATING ERRORS

Malfunions in the system which are caused by range exceeding or operating errors by the crane operator himself are indicated on the display together with an explanation. These error codes are E01, E02, E03, E04, and E05 and they can normally be eliminated by the crane operator himself.

Error Code	Cause	Elimination
<b>E01</b>	Fallen below the minimum radius or above the angle given in the load capacity chart due to luffing up the boom too far.	Boom down to a radius or angle given in the load capacity chart.
<b>E02</b>	The maximum radius or minimum angle given in the load capacity chart was exceeded due to luffing down the boom too far.	Boom up to a radius or angle given in the load capacity chart.
<b>E03</b>	Boom position is out of the permissible working area (over front).	Move boom back to the permissible working area. See lifting diagram in the load capacity charts.
<b>E04</b>	Operating mode switch in the console incorrectly set.	Correctly set operating mode switch to the code assigned to the operating mode of the crane.
	Operating mode is not permissible with the actual crane configuration, boom position or area definition.	Be sure crane is set up according to proper operating configurations.
<b>E05</b>	Boom was telescoped too far or not far enough, you may only operate up to a certain maximum or minimum boom length or with load curves for boom extension where you have to telescope the main boom to a certain length.	Telescope boom to correct length, given in the load capacity chart.
	Length sensor adjustment changed i.e. length sensor cable slid off the length sensor drum.	For elimination refer to service manual.