

ITEM	PART NUMBER	DESCRIPTION	QTY
1	031-300-100-112	JUNCTION BOX ASS'Y, 2 PIN/SKT RECPT AND STRAIN RELIEF	1
2	031-300-100-110	CONDUIT, 1/4", (PER FOOT)	1.7'
3	031-002-060-011	A2B SWITCH WITH CRIMP	1

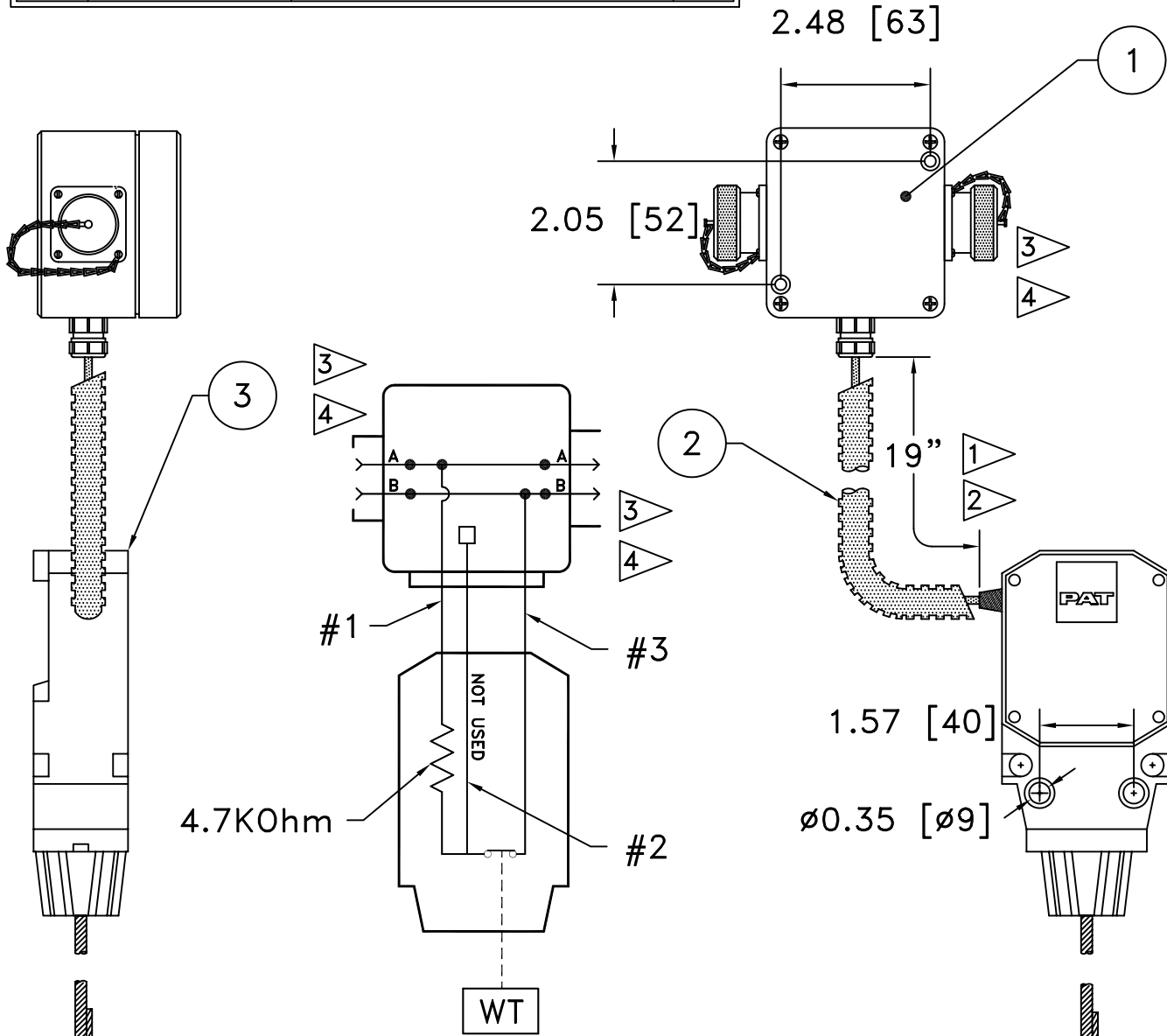

NOTES:

- 1 CABLE LENGTH WILL BE 19 INCHES MAXIMUM AND 18.5 INCHES MINIMUM. MEASURE FROM THE END OF THE RUBBER GROMMET ON THE A2B SWITCH TO THE STRAIN RELIEF ON THE RECEPTACLE, WITH NO SLACK IN THE CABLE.
- 2 THE CONDUIT LENGTH WILL BE EQUAL TO THE CABLE LENGTH, WITH A MAXIMUM GAP OF .25 INCHES WHEN MEASURED AS FOLLOWS:
A. PUSH CONDUIT FIRMLY AGAINST THE RUBBER GROMMET ON THE A2B SWITCH.
B. MAXIMUM GAP ALLOWED FROM STRAIN RELIEF TO CONDUIT IS .25 INCHES.
- 3 ROTATE NOTCH OF RECEPTACLE SO IT IS IN THE 12 OCLOCK POSITION.
- 4 COVER ALL SOLDERED CONNECTIONS WITH 1/8" HEATSHRINK TUBING (COLEFLEX STS221 OR EQUIVALENT)

IS = INNER SHIELD
OS = OUTER SHIELD
NC = NOT CONNECTED

		PAT AMERICA, Inc. 1665 ORCHARD DRIVE CHAMBERSBURG, PA 17201			A2B SWITCH ASSEMBLY WITH JUNCTION BOX & 2 PIN/SKT RECPT		
		GENERAL X.XX = 0.01 TOLERANCES X.XXX = 0.005	P/N 531-300-100-113	DRAWN REL 05/13/94	APPROVED CHRIS HERTZLER 08/10/01	SCALE: NONE SHEET: 1 OF 1	SIZE DWG NO. A 531 300 10 0113 B
REV ECN DESCRIPTION BY APV DATE	B 01-277 NOTES ADDED FOR OUTSOURCING SB CSH 10/3/01	A 01-240 DELETE SWITCH DIMENSION; ADD MOUNTING DIMENSIONS CSH CSH 08/10/01	PAT America Inc. reserves proprietary rights to this drawing and to the data shown thereon. The drawing and data are confidential and are not to be used or reproduced without the written consent of PAT America Inc. This drawing is subject to technical modification without prior notice.	C.A.G.E. 79760	A 531 300 10 0113 B	REV	