

LEGEND	
BRN	BROWN
BLK	BLACK
WHT	WHITE
GRY	GRAY
GRN	GREEN
BLU	BLUE
RED	RED
PNK	PINK
ORG	ORANGE
YEL	YELLOW
VIO	VIOLET
SHD	SHIELD
GRN/ YEL	GREEN YELLOW
IS	INNER SHIELD
SS	SINGLE SHIELD
DS	DOUBLE SHIELDED
NC	NORMALLY CLOSED
NO	NORMALLY OPEN

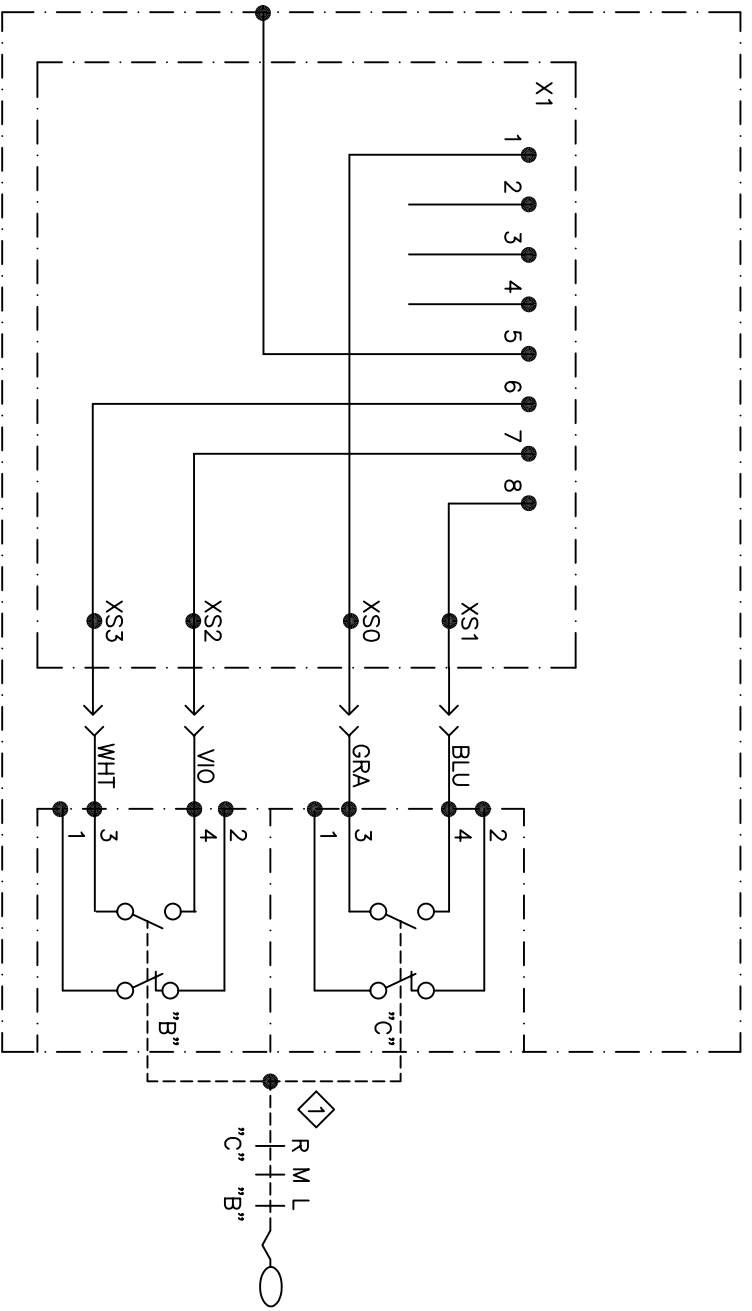

NOTES:

MODIFY THE KEY SWITCH WIRING OF CONSOLE P/N 050-350-061-219 AS SHOWN TO MEET (CE) CONFORMITY.

THIS MODIFIED CONSOLE HAS BEEN ASSIGNED A DOMESTIC P/N 031-300-100-996 IF/UNTIL PAT GmbH ASSIGNS A P/N

PAT		PAT EQUIPMENT CORPORATION		1219 CONSOLE MODIFICATION	
1665 ORCHARD DRIVE		CHAMBERSBURG, PA 17201		TO MEET (CE) CONFORMITY	
REV.	ECN	DESCRIPTION	NAME	DATE	DRAWN
					APPROVED
					SCALE: NONE
					SHEET 1 OF 1
					REV NO.
					DWG NO. ERN95-11
					C.A.G.E. 79760
					MAKE STAKE
					6-29-95

PAT Equipment Corporation reserves proprietary rights to the drawing and to the data shown hereon. The drawing and data are confidential information and shall remain the property of PAT Equipment Corporation. This drawing is subject to unnoted modification without prior notice.