

# ELECTRICAL DIAGRAM

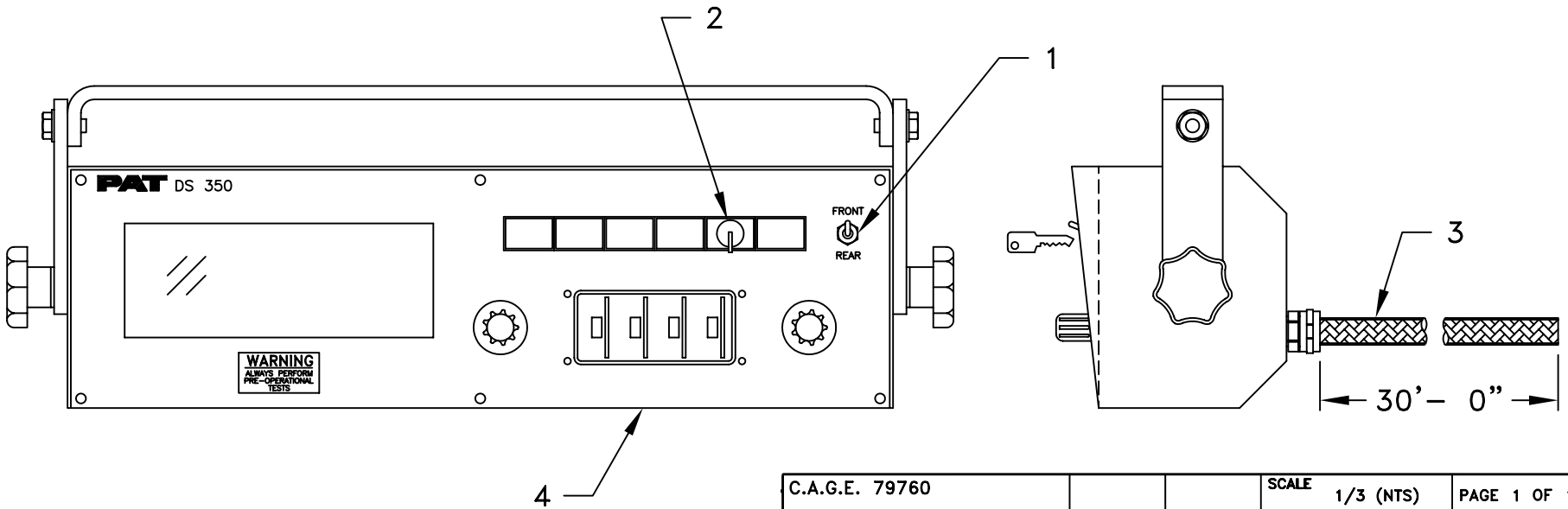
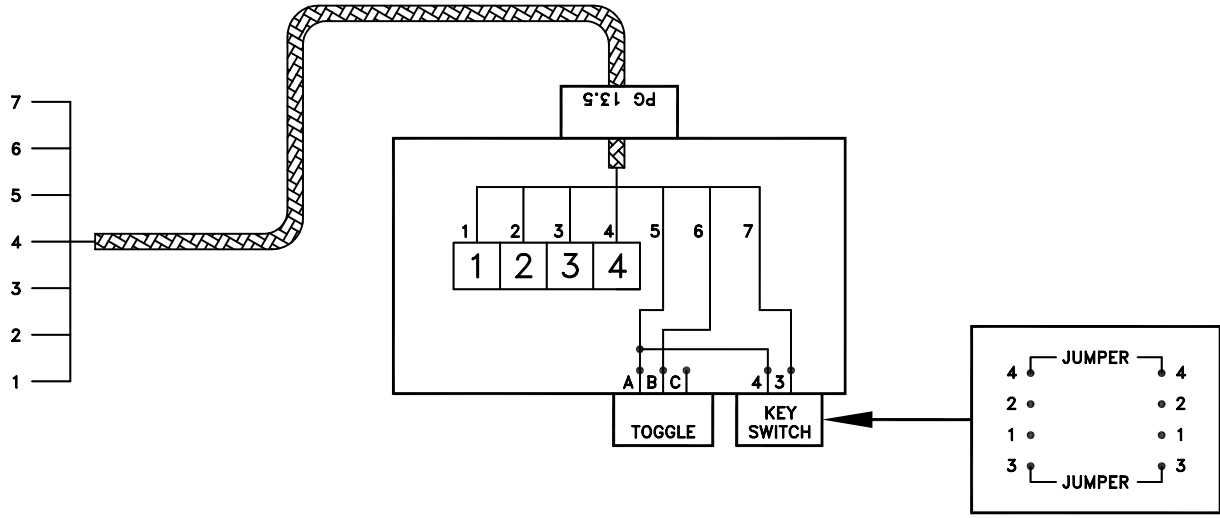

ITEM	PART NUMBER	DESCRIPTION	QTY
1	050-000-100-031	SWITCH, HOIST SELECTOR	1
2	003-051-903-364	SWITCH, KEY, LUMITAS - DS 350G	1
3	031-300-100-149	CABLE, 7 x 0.5 S.S. (PER FOOT)	30'
4	050-350-061-229	CONSOLE, DS350, L.B., HORIZONTAL	1

C.A.G.E. 79760				SCALE 1/3 (NTS)		PAGE 1 OF 1	
MATERIAL							
<b>CONSOLE ASS'Y</b>							
DS 350 HORIZONTAL 031-300-100-889							
REV.	DESCRIPTION	DATE	NAME	DATE	NAME		
				9/8/94	RLE		
				<b>PAT EQUIPMENT CORPORATION</b> 1665 ORCHARD DRIVE CHAMBERSBURG, PA 17201			
<small>PAT Equipment Corporation reserves proprietary rights to this drawing and to the data shown thereon. The drawing and data are confidential and are not to be used or reproduced without the written consent of PAT Equipment Corporation. This drawing is subject to technical modification without prior notice.</small>							
LTC25-10							