

ITEM	PART NUMBER	QTY	DESCRIPTION
1	031-300-050-450	1	CONNECTOR, AMPHENOL PLUG 6+PET3104 101 PIN
2	1-0010574.00	1	CABLE CONN PG11 GRAY
3	031-300-050-606	1	SENSOR, ANGLE SSY0185-45 WITH 25 FT. OF CABLE
4	031-300-050-561	1	DECAL, PRS35ez ANGLE SENSOR

REV	ECN	DESCRIPTION	BY	APV	DATE

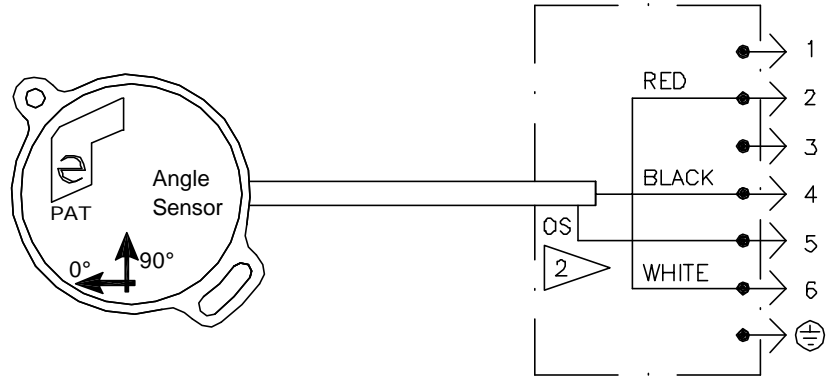
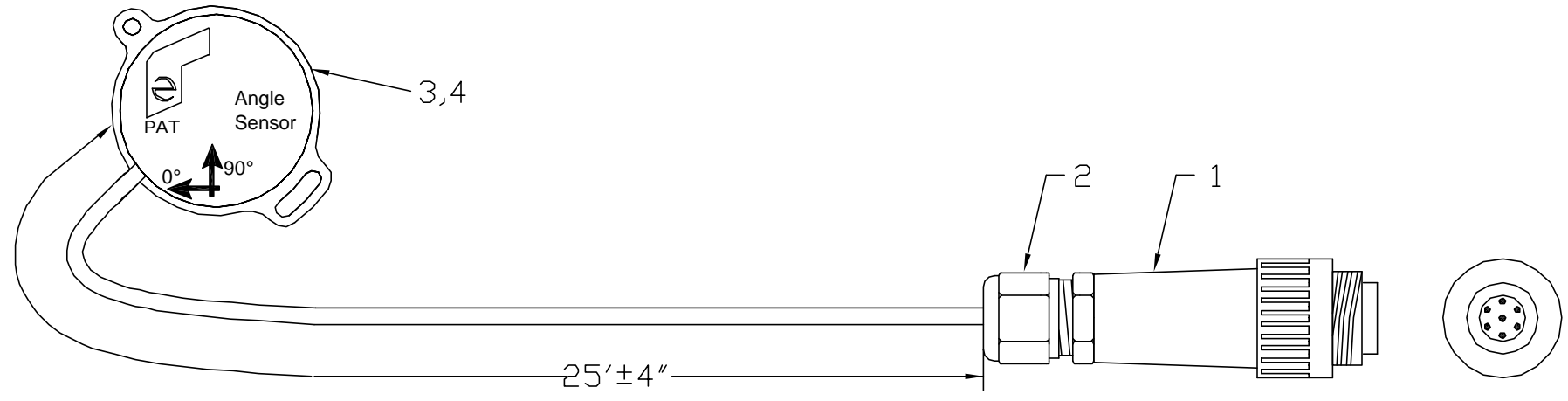

- NOTES:
- 1 OUTER SHIELD GROUNDED AT STRAIN RELIEF INSERT
 - 2 SOLDER AN INSULATED WIRE TO SHIELD AND CONNECTED AS SHOWN.
 - 3 CUT AND INSULATE INNER SHIELD/WIRE
 - 4 COVER ALL SOLDERED CONNECTIONS WITH 1/8" HEATSHRINK TUBING (COLEFLEX STS221 OR EQUIVALENT)
 - 5 ADD DIELECTRIC LUBRICANT (e.g. NYOGEL 759G) TO INSIDE OF RECEPTACLES, PLUGS, AND ELECTRICAL CONNECTORS, TO IMPROVE PROTECTION AGAINST CORROSION AND MALFUNCTION DUE TO CONDENSATION.

IS = INNER SHIELD
 OS = OUTER SHIELD
 NC = NOT CONNECTED

Hirschmann ECS Division PAT AMERICA, Inc. 1865 ORCHARD DRIVE CHAMBERSBURG, PA 17201	TITLE ANGLE SENSOR ASSY, 25' WITH 7-PIN PLUG	
	GENERAL TOLERANCES: ECN: 04-092 031-300-060-695	
W. DIM. DEC. PLACES MM DIM. ±0.1* 1 PLACE DEC. ±2.5mm ±0.01* 2 PLACE DEC. ±0.25mm ±0.005* 3 PLACE DEC. ±0.13mm 1/16" FRACTION ±1.5mm	DRAWN: MIKE STAKE APPROVED: [Signature] SCALE: NONE DWG NO. 031 300 06 0695	DATE: 05.21.04 SHEET: 1 OF 1 REV: -

PAT America, Inc. reserves proprietary rights to this drawing and to the data shown thereon. The drawing and data are confidential and are not to be used or reproduced without the written consent of PAT America, Inc. This drawing is subject to technical modification without notice.

C.A.G.E. 79760