

REV	ECN	DESCRIPTION	BY	APV	DATE
B	05-067	REMOVED 155' CABLE LENGTH REF; NEW TITLEBLOCK	MWS		04.18.05

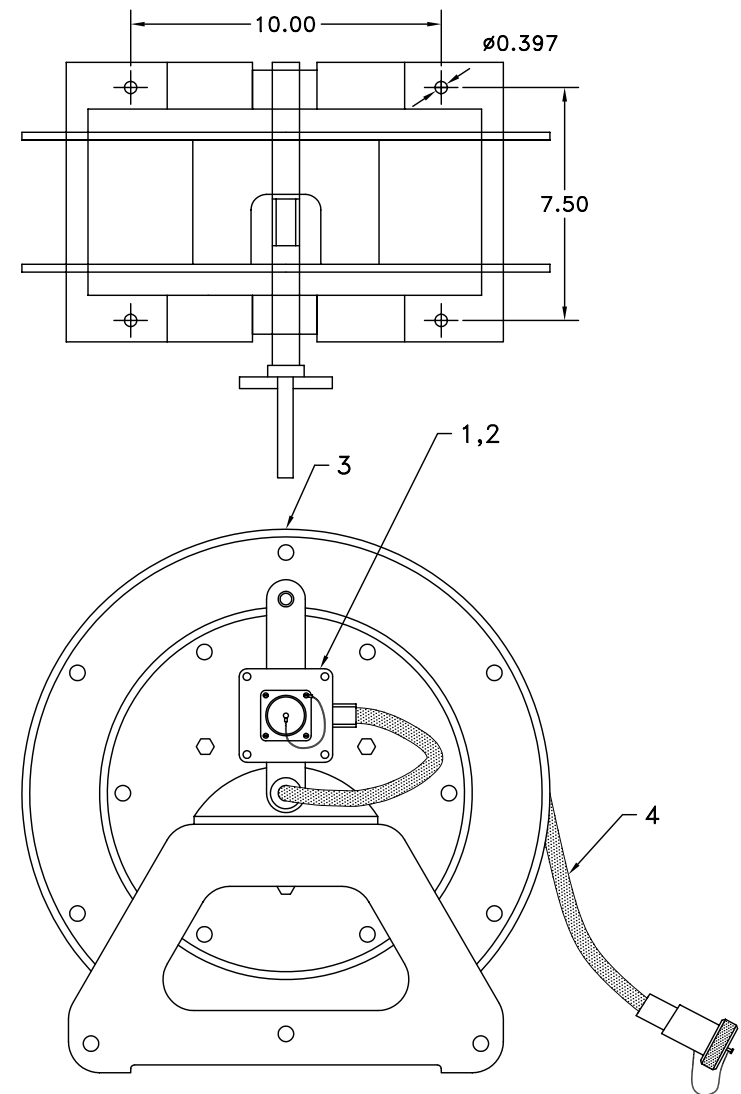
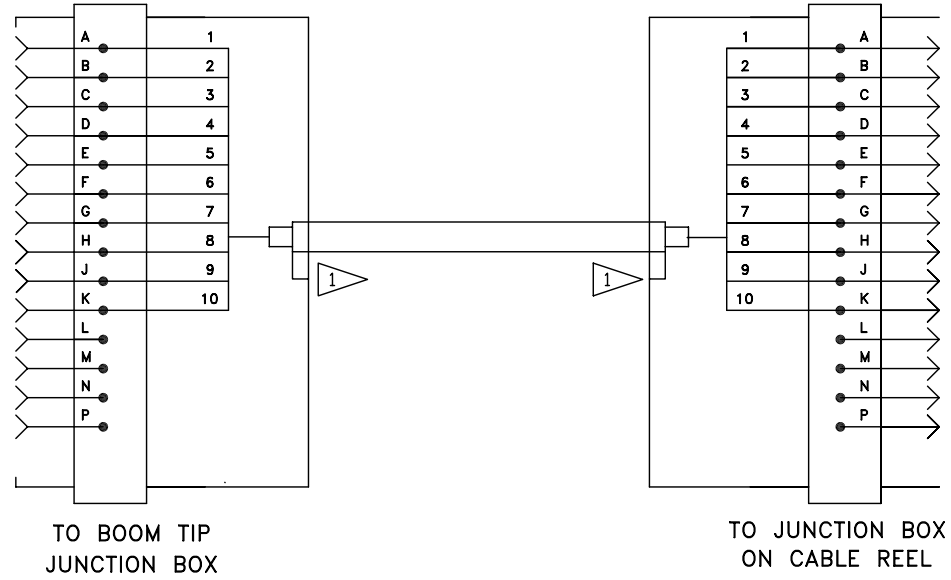

ITEM	PART NUMBER	DESCRIPTION	QTY
1	031-300-060-027	JUNCTION BOX ASSY, 80X70 LATTICE REEL	1
2	031-300-100-667	SCREW, 8-32X3/4 SOCKET HEAD	2
3	031-300-050-231	CABLE REEL, LATTICE, MAIN BOOM	1
4	031-300-110-095	CABLE ASSY, 170' 10 COND W/14 SOCKET PLUG	1

NOTES:

- 1 OUTER SHIELD GROUNDED AT STRAIN RELIEF INSERT
- 2 SOLDER AN INSULATED WIRE TO INNER SHIELD AND CONNECTED AS SHOWN.
- 3 CUT AND INSULATE INNER SHIELD/WIRE
- 4 COVER ALL SOLDERED CONNECTIONS WITH 1/8" HEATSHRINK TUBING (COLEFLEX STS221 OR EQUIVALENT)
- 5 ADD DIELECTRIC LUBRICANT (e.g. NYOGEL 759G) TO INSIDE OF RECEPTACLES, PLUGS, AND ELECTRICAL CONNECTORS, TO IMPROVE PROTECTION AGAINST CORROSION AND MALFUNCTION DUE TO CONDENSATION.

IS = INNER SHIELD

 Hirschmann Electronics, Inc. ECS Division 1605 ORCHARD DRIVE CHAMBERSBURG, PA 17201	TITLE CABLE REEL ASSEMBLY W/ 10 COND. CABLE												
	GENERAL TOLERANCES <table border="1"> <tr> <td>$\pm 0.1"$</td> <td>1 PLACE DEC.</td> <td>$\pm 2.5\text{mm}$</td> </tr> <tr> <td>$\pm 0.01"$</td> <td>2 PLACE DEC.</td> <td>$\pm 0.25\text{mm}$</td> </tr> <tr> <td>$\pm 0.005"$</td> <td>3 PLACE DEC.</td> <td>$\pm 0.13\text{mm}$</td> </tr> <tr> <td>1/16"</td> <td>FRACTION</td> <td>$\pm 1.5\text{mm}$</td> </tr> </table>		$\pm 0.1"$	1 PLACE DEC.	$\pm 2.5\text{mm}$	$\pm 0.01"$	2 PLACE DEC.	$\pm 0.25\text{mm}$	$\pm 0.005"$	3 PLACE DEC.	$\pm 0.13\text{mm}$	1/16"	FRACTION
$\pm 0.1"$	1 PLACE DEC.	$\pm 2.5\text{mm}$											
$\pm 0.01"$	2 PLACE DEC.	$\pm 0.25\text{mm}$											
$\pm 0.005"$	3 PLACE DEC.	$\pm 0.13\text{mm}$											
1/16"	FRACTION	$\pm 1.5\text{mm}$											
Hirschmann Electronics, Inc. reserves proprietary rights to this drawings and to the data shown thereon. The drawing and data are confidential and are not to be used or reproduced without the written consent of Hirschmann Electronics, Inc. This drawing is subject to technical modification with out notice.		DWG NO. 031 300 06 0227											
C.A.G.E. 79760		APPROVED CHRIS HERTZLER 03/10/00 SCALE: NONE SHEET: 1 OF 1											